

Problem Set 8
409 - Discrete Optimization
 Winter 2026

Exercise 1 (10 points)

Run the Branch & Bound algorithm to solve the following integer linear program

$$\begin{aligned} \max \quad & 3x_1 + x_2 \\ -2x_1 + 3x_2 \leq & 6 \\ 10x_1 + 4x_2 \leq & 27 \\ x_1 \geq & 0 \\ x_2 \geq & \frac{1}{2} \\ x_1, x_2 \in & \mathbb{Z} \end{aligned}$$

Also give the Branch & Bound tree.

Hint. For convinience, the underlying polytope looks as follows:

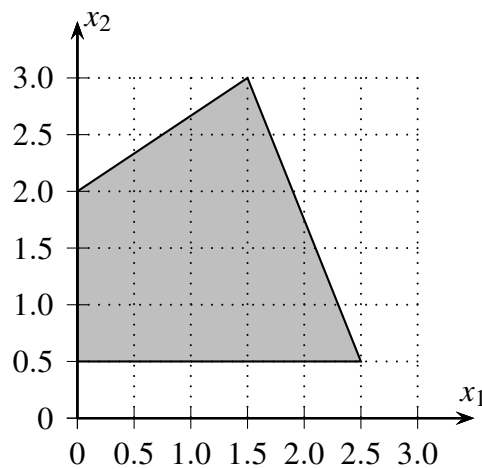

Exercise 2 (10 points)

Let $G = (V, E)$ be an undirected graph. For $U \subseteq V$, let $\text{odd}(U)$ be the number of connected components in $G \setminus U$ that have an odd number of vertices. Below is a schematic picture.

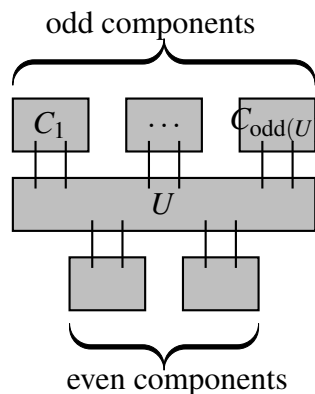

a) In the example graph below, find a node set U so that $\text{odd}(U) > |U|$.

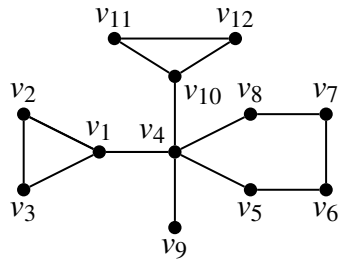

Remark: Note that together with b), this proves that this particular graph does not contain a perfect matching.

b) Now consider an arbitrary graph $G = (V, E)$. Prove that if there is a set $U \subseteq V$ with $\text{odd}(U) > |U|$, then G does not contain a perfect matching.