

Due: Tue Oct 11 2016 11:58 PM PDT

Question

1 2 3 4 5

1. Question Details

UWAPreCalc1 3.P.001. [2125213]

This exercise emphasizes the "mechanical aspects" of circles and their equations.

(a) Find an equation whose graph is a circle of radius 3 centered at $(-4, 4)$.

(b) Find an equation whose graph is a circle of diameter $\frac{1}{2}$ centered at the point $(3, -\frac{5}{3})$.

(c) Find the equations for two different circles with radius 5 which pass through the point $(1, 1)$. (Enter your answers as a comma-separated list.)

(d) Consider the equation $(x - 1)^2 + (y + 1)^2 = 4$. Which of the following points lie on the graph of this equation? (Select all that apply.)

- $(0, 0)$
- $(1, -1)$
- $(0, -1 - \sqrt{3})$
- $(1 + \sqrt{3}, 0)$
- $(1, 1)$
- $(1, -3)$

2. Question Details

UWAPreCalc1 3.P.003. [2125181]

Water is flowing from a major broken water main at the intersection of two streets. The resulting puddle of water is circular and the radius r of the puddle is given by the equation $r = 6t$ feet, where t represents time in seconds elapsed since the main broke.

(a) When the main broke, a runner was located 5 miles from the intersection. The runner continues toward the intersection at the constant speed of 16 feet per second. When will the runner's feet get wet?

 min

(b) Suppose, instead, that when the main broke, the runner was 5 miles east, and 5000 feet north of the intersection. The runner runs due west at 16 feet per second. When will the runner's feet get wet? (Round your answer to one decimal place.)

 min

3. Question Details

An amusement park Ferris Wheel has a radius of 70 feet. The center of the wheel is mounted on a tower 74 feet above the ground (see picture). For these questions, the wheel is not turning.

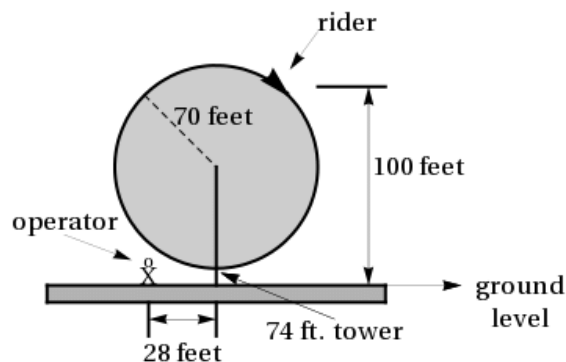

(a) Impose a coordinate system. (Let one unit equal one foot.)

- Imposing with the x -axis along the ground and the y -axis along the tower, the wheel is modeled by $(x - 74)^2 + y^2 = 70^2$.
- Imposing with the x -axis along the ground and the y -axis along the tower, the wheel is modeled by $x^2 + (y - 70)^2 = 74^2$.
- Imposing with the x -axis along the tower and the y -axis along the ground, the wheel is modeled by $x^2 + (y - 74)^2 = 70^2$.
- Imposing with the x -axis along the tower and the y -axis along the ground, the wheel is modeled by $x^2 + (y - 70)^2 = 74^2$.
- Imposing with the x -axis along the ground and the y -axis along the tower, the wheel is modeled by $x^2 + (y - 74)^2 = 70^2$.

(b) Suppose a rider is located at the point in the picture, 100 feet above the ground. If the rider drops an ice cream cone straight down, where will it land on the ground? (Round your answer to one decimal place as needed.)

$$(x, y) = \left(\boxed{} \right)$$

(c) The ride operator is standing 28 feet to one side of the support tower on the level ground at the location in the picture. Determine the locations of a rider on the Ferris Wheel so that a dropped ice cream cone lands on the operator. (Note: There are two answers. Round your answers to one decimal place as needed.)

$$(x, y) = \left(\boxed{} \right) \text{ (smaller } y\text{-value)}$$

$$(x, y) = \left(\boxed{} \right) \text{ (larger } y\text{-value)}$$

Erik's disabled sailboat is floating stationary 3 miles east and 2 miles north of Kingston. A ferry leaves Kingston heading toward Edmonds at 12 mph. Edmonds is 6 miles due east of Kingston. After 20 minutes, the ferry turns, heading due south. Ballard is 8 miles south and 1 mile west of Edmonds. Impose coordinates with Ballard as the origin. (Let one unit equal one mile.)

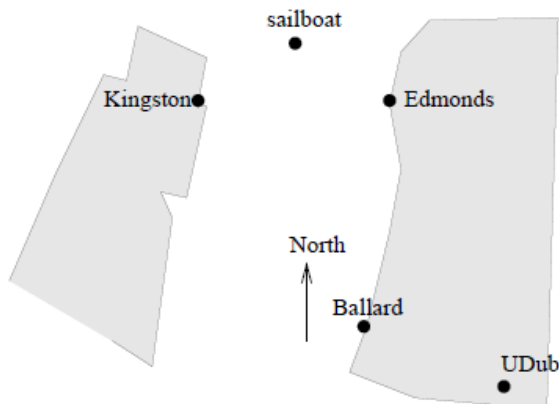

(a) Find the equations for the lines along which the ferry is moving.

eastward

southward

Draw in these lines.

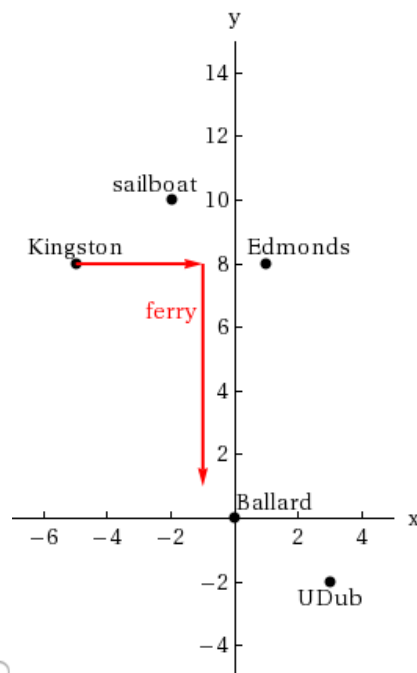
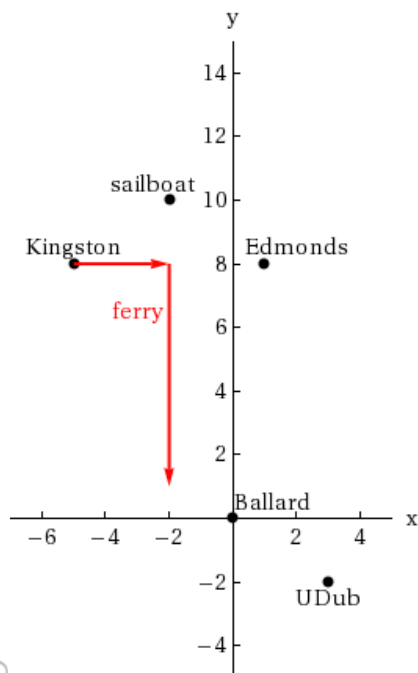

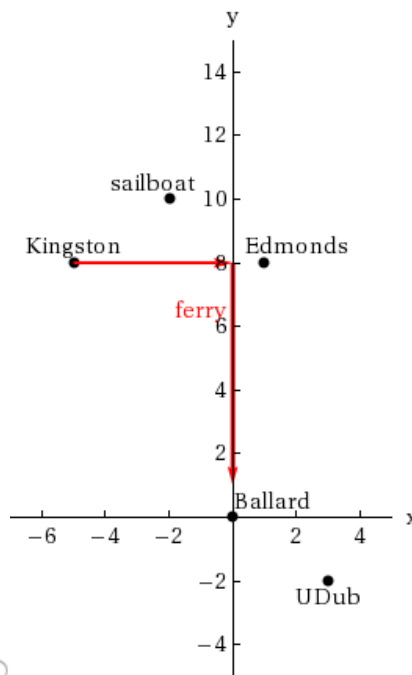
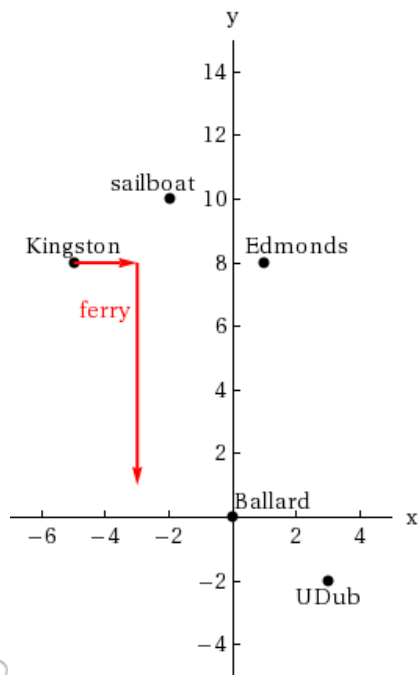

(b) The sailboat has a radar scope that will detect any object within 3 miles of the sailboat. Looking down from above, as in the picture, the radar region looks like a circular disc. The *boundary* is the "edge" or circle around this disc, the *interior* is the inside of the disc, and the *exterior* is everything outside of the disc (i.e., outside of the circle). Give a mathematical description of the boundary, interior, and exterior of the radar zone. (Express your answers as equations and/or inequalities using the variables x and y .)

boundary

interior

exterior

Sketch an accurate picture of the radar zone by determining where the line connecting Kingston and Edmonds would cross the radar zone.

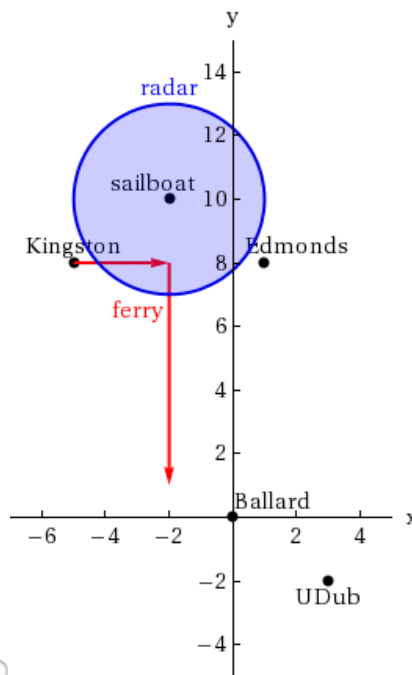
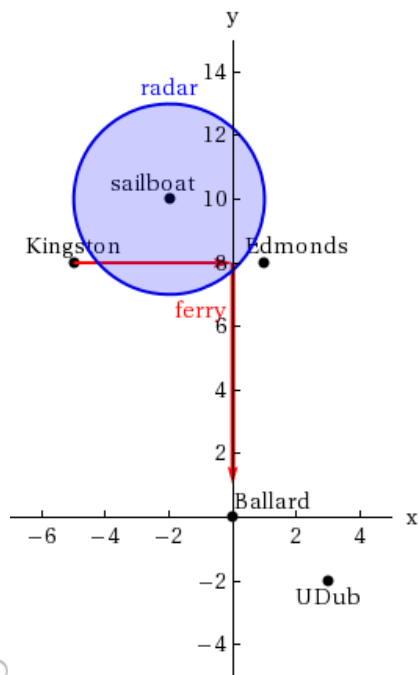

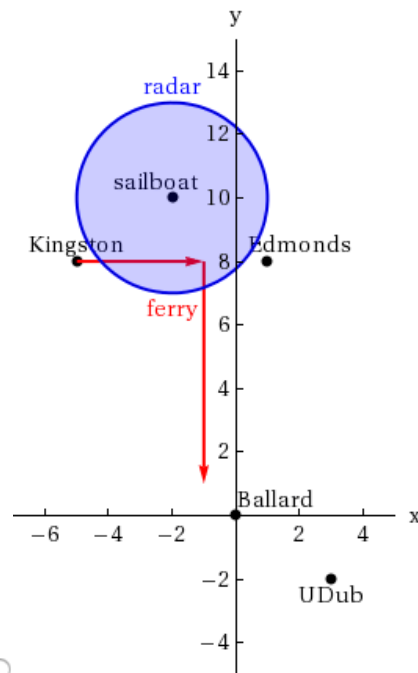
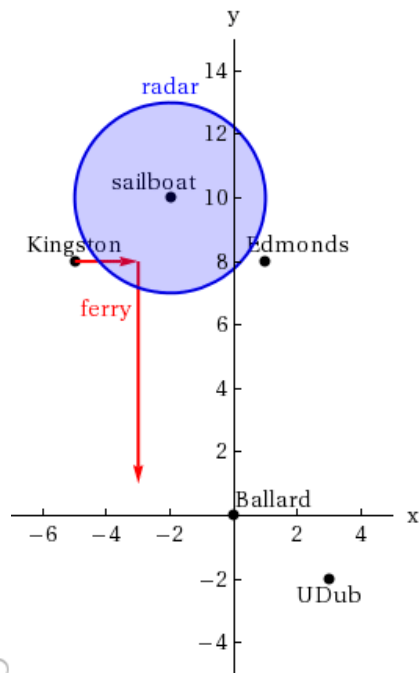

(c) When does the ferry enter the radar zone? (Round your answer to one decimal place.)

min

(d) Where does the ferry exit the radar zone? (Round your answers to one decimal place as needed.)

$(x, y) = ($ $)$

When does the ferry exit the radar zone? (Round your answer to one decimal place.)

min

(e) How long does the ferry spend inside the radar zone? (Round your answer to one decimal place.)

min

5. Question Details

Nora spends part of her summer driving a *combine* during the wheat harvest. Assume she starts at the indicated position heading east at 10 ft/sec toward a circular wheat field of radius 200 ft. The combine cuts a swath 20 feet wide and begins when the corner of the machine labeled "a" is 50 feet north and 50 feet west of the western-most edge of the field. (Round your answers to one decimal place.)

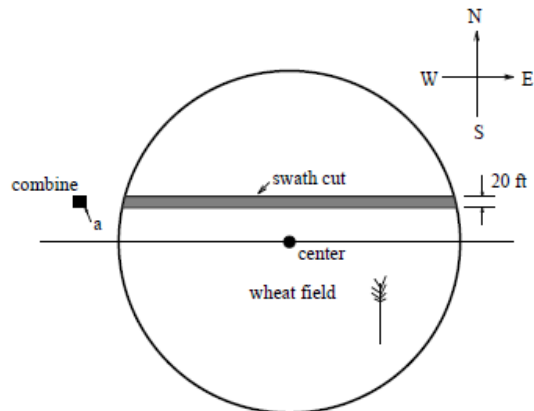

(a) When does Nora's rig first start cutting the wheat?

sec

(b) When does Nora's rig first start cutting a swath 20 feet wide?

sec

(c) Find the total amount of time wheat is being cut during this pass across the field.

sec

(d) Estimate the area of the swath cut during this pass across the field.

ft²

Assignment Details