

Math 126, Sections D and F, Spring 2012, Midterm I

April 19, 2012

Name _____

TA/Section _____

Instructions.

- There are 4 questions. The exam is out of 40 points. Answer the questions you are comfortable with first.
- You are allowed to use one page of notes written only on one side of the sheet in your own handwriting. **Hand in your notes with your exam paper.**
- You may use a calculator which does not graph and which is not programmable. Even if you have a calculator, give me exact answers. ($\frac{2\ln 3}{\pi}$ is exact, 0.7 is an approximation for the same number.)
- **Show your work.** If I cannot read or follow your work, I cannot grade it. You may not get full credit for a right answer if your answer is not justified by your work. If you continue at the back of a page, make a note for me. Please BOX your final answer.

Question	points
1	
2	
3	
4	
Total	

1. The following questions regard the parallelepiped shown below. The figure is not to scale. The following vectors are known: $\vec{AC} = \langle 0, 5, 2 \rangle$, $\vec{AD} = \langle -14, 3, 7 \rangle$ and $\vec{AB} = \langle 1, 3, 4 \rangle$.

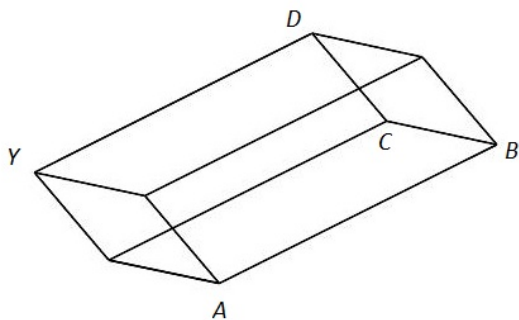

- (a) (4 points) Compute the vector \vec{CD} and the angle between \vec{AC} and \vec{CD} .

- (b) (4 points) Compute the area of the triangle with vertices A , C and D .

- (c) (3 points) If the point A is at $(2, 1, 0)$, find the coordinates of the point Y .

2. For the following pairs of line and plane equations, write one of SKEW, PERPENDICULAR, PARALLEL or THE SAME to finish each sentence. (2 points each. 1 point for the answer, 1 point for a brief explanation or computation.)

(a) The planes $x + y - z = 3$ and $2x + 2y - 2z = 6$ are _____.

(b) The planes $2x - 4y + 6z = 7$ and $-x + 2y - 3z = 9$ are _____.

(c) The lines $\mathbf{r}_1(t) = \langle 4, 1 + t, 3 \rangle$ and $\mathbf{r}_2(t) = \langle t, 2t, 5t \rangle$ are _____.

(d) The lines $\mathbf{r}_1(t) = \langle 2 - 3t, 4 + t, 7 + 2t \rangle$ and $\mathbf{r}_2(t) = \langle 5 + 6t, 3 - 2t, 5 - 4t \rangle$ are _____.

(e) The plane $4x - 7y + z = 3$ and the line $\mathbf{r}(t) = \langle 4t, 8 - 7t, 5 + t \rangle$ are _____.

3. Answer the following questions about space curves.

- (a) (1 point each) Match the following vector functions with the space curves they represent. Think of the surfaces they are on to help you identify the graphs. Write the letter of the graph next to the equation.

$\mathbf{r}_1(t) = \langle t, 3 + 4 \sin(t), 4 \rangle$ _____ $\mathbf{r}_2(t) = \langle \sin(t) \cos(14t), \sin(t) \sin(14t), \cos(t) \rangle$ _____

$\mathbf{r}_3(t) = \langle t \cos(5t), t^2, t \sin(5t) \rangle$ _____ $\mathbf{r}_4(t) = \langle t^2 + 1, t, t^3 - 6t + 4 \rangle$ _____

The labels x , y and z are next to the positive axes.

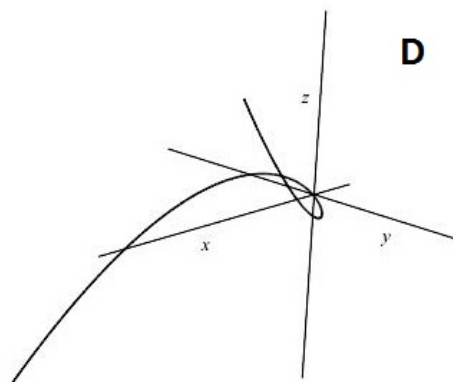
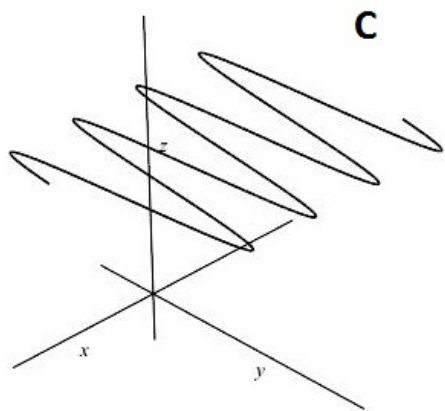
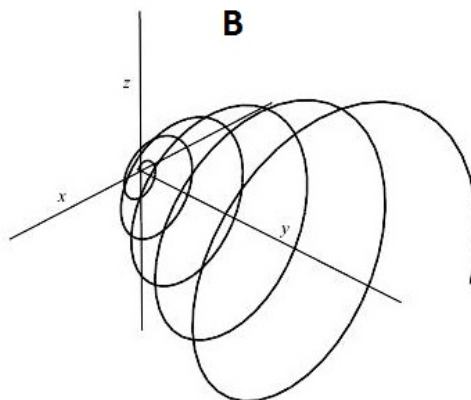
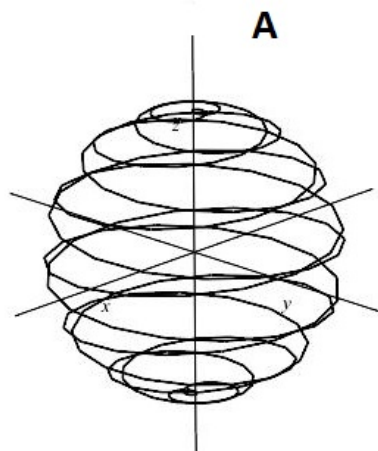

- (b) (5 points) Find parametric equations of the tangent line to the curve given by $\mathbf{r}_1(t) = \langle t, 3 + 4 \sin(t), 4 \rangle$ at the point $(0, 3, 4)$.

4. Answer the following.

- (a) (4 points) Identify the following surface and make a sketch of it. Your picture does not have to be drawn to scale. I am only interested in seeing the shape and orientation.

$$x^2 + 4y^2 - 24y - 4z + 20 = 0$$

- (b) (6 points) Find the equation of the tangent lines to the three leaved rose $r = \sin(3\theta)$ at the point A which is at the tip of its left petal as marked with a dot in the picture.

