

## Worksheet for Week 7: Related Rates

This worksheet guides you through some more challenging problems about related rates.

A milk carton is shaped like a tall box with a triangular prism on top. The sides of the top section are isosceles triangles. This particular milk carton has a 5 inch  $\times$  5 inch square base, and is 11 inches tall. (See the picture.)

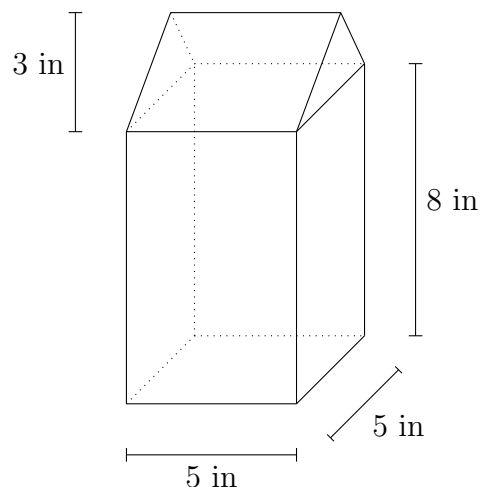

Suppose you're filling the carton with liquid, at a rate of 10 inches<sup>3</sup> per minute. In this problem, you'll figure out the rate of change of the height of the liquid in the carton, at the instant when the carton holds 220 inches<sup>3</sup> of liquid.

1. (a) Let  $y$  be the height of the liquid in the carton. Then  $y$  is a function of time, because  $y$  is changing as more liquid pours in. Suppose  $y \leq 8$ , so that the liquid is all in the rectangular part of the carton. Find a formula for the total volume of liquid in the carton.

**Solution:**  $V = 5 \cdot 5 \cdot y = 25y \text{ in}^3$ .

- (b) Now suppose  $8 \leq y \leq 11$ , so that some liquid is in the triangular part of the carton. Find a formula for the total volume of liquid in the carton, in terms of  $y$ . You might want to break up the volume into two pieces: the volume below the 8-inch line and the volume above the 8-inch line.

**Solution:** Volume below 8-inch line:  $5 \cdot 5 \cdot 8 = 200 \text{ in}^3$ .

Volume between 8 and  $y$  inches: see the picture, and remember that the height of the triangle is 3, and the base is 5. Let  $h = y - 8$ . The two similar triangles tell us that

$$\frac{3-h}{b} = \frac{3}{5},$$

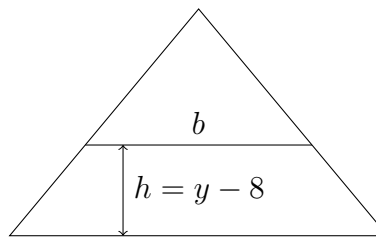

So  $b = 5 - \frac{5}{3}h$ . The area of the trapezoid is then  $\frac{1}{2}(5 + (5 - \frac{5}{3}h))h = 5y - \frac{5}{6}h^2$ , so the volume of the liquid above 8 inches is  $5(5h - \frac{5}{6}h^2)$ .

Putting it all together, and setting  $h = y - 8$ , the total volume is  $200 + 5(5(y - 8) - \frac{5}{6}(y - 8)^2) \text{ in}^3$ .

- (c) Next, suppose that  $220 \text{ in}^3$  of liquid is in the carton. How high is the liquid level? That is, what is  $y$ ?

**Solution:** If  $V = 220$ , then  $y > 8$ , since the volume below 8 inches is  $200 \text{ in}^3$ . So the formula we found for the volume in the triangular prism,  $5(5h - \frac{5}{6}h^2)$ , must be equal to 20. (The only point of using  $h = y - 8$  instead of  $y$  is to avoid dealing with the volume below 8 inches, since we have already subtracted it off.) Simplifying and clearing denominators, we get the quadratic equation

$$5h^2 - 30h + 24 = 0,$$

which has solutions  $h \approx 0.95$  and  $h \approx 5.05$ . But  $h$  can't equal 5.05, because then  $y = h + 8$  would be bigger than 11, and 11 inches is the top of the milk carton. So  $h \approx 0.95$  is our solution. Thus  $y = h + 8 \approx 8.95$  is the liquid level when  $V = 220 \text{ in}^3$ .

- (d) What is  $\frac{dy}{dt}$  when  $220 \text{ in}^3$  of liquid is in the carton?

**Solution:** Use the formula from part (b). We have  $V = 200 + 5(5(y - 8) - \frac{5}{6}(y - 8)^2)$ , so we differentiate with respect to  $t$ . ( $V$  and  $y$  are both functions of  $t$ .) We get

$$\frac{dV}{dt} = 5 \left( 5 \frac{dy}{dt} - \frac{5}{6} \cdot 2(y - 8) \frac{dy}{dt} \right)$$

Now  $\frac{dV}{dt} = 10 \text{ in}^3/\text{min}$ , so plug that in and solve for  $\frac{dy}{dt}$ :

$$\frac{dy}{dt} = \frac{2}{5 - \frac{5}{3}(y - 8)}$$

We saw in part (c) that  $y \approx 8.95$  at the instant when  $V = 220 \text{ in}^3$ , so plug that in too. We find that

$$\frac{dy}{dt} \approx 0.585 \text{ in}/\text{min}.$$

- (e) When  $y$  reaches 8 inches, does  $\frac{dy}{dt}$  increase, decrease, or stay the same? You can answer this question by using the formulas you found on Page 1, or by looking at the picture. How do you know your answer is correct?

**Solution:** At  $y = 8$ ,  $\frac{dy}{dt}$  increases. The liquid is pouring in at a constant rate, but the container is shrinking, so it will fill up faster towards the top.

2. Now suppose a funnel is positioned over a coffee mug.

The funnel is a cone 3 inches high with a base radius of 2 inches, and the coffee mug is 4 inches tall with a 1.5-inch radius. See the picture at right.

Suppose the funnel is initially **full** of coffee. Then it starts to drip down into the mug at a constant rate of 0.1 inches<sup>3</sup> per second.

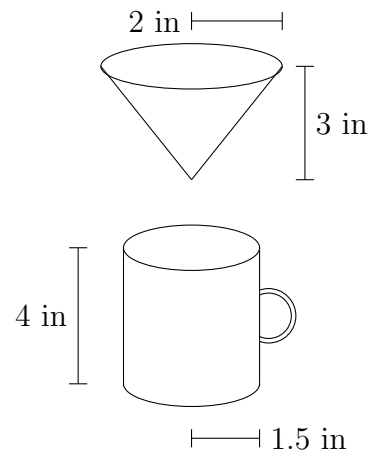

- (a) Let  $y$  be the height of the coffee in the funnel at any given time, so that just before the dripping starts we have  $y = 3$ . Since the coffee is draining out of the funnel,  $\frac{dy}{dt}$  will be negative. What (approximately) will be the value of  $y$  when  $\frac{dy}{dt}$  is at its smallest (closest to zero)?

**Solution:** Around  $y = 3$ : the height  $y$  will change the slowest when the coffee level is at the top of the cone.

- (b) What (approximately) will  $y$  be when  $\frac{dy}{dt}$  is biggest (farthest from zero)?

**Solution:** At about  $y = 0$ , the bottom of the funnel. The coffee drips out at a constant rate, so the coffee level will change the fastest at the narrowest part of the cone.

- (c) How much coffee is in the funnel at the very beginning?

**Solution:** Use the volume formula for a cone:

$$\begin{aligned} V &= \frac{1}{3}\pi r^2 h \\ &= \frac{1}{3}\pi(2)^2(3) \\ &= 4\pi \\ &\approx 12.57 \text{ inches}^3. \end{aligned}$$

- (d) How much coffee is in the funnel **and mug** at some time  $t$ ?

**Solution:** Same as part (c); the problem starts with all the coffee it will ever have.

- (e) Find a formula, depending on the height  $y$  of coffee in the funnel, for the volume of coffee in the funnel.

**Solution:** We need to find the radius of the surface of the coffee, given only that the height of the coffee is  $y$ . Again, we use similar triangles. If  $p$  is the radius of the surface of the coffee, then we have

$$\frac{3}{2} = \frac{y}{p},$$

from which we get that  $p = \frac{2}{3}y$ . Now the volume when the coffee is at height  $y$  can be found by the same formula as above:  $V = \frac{1}{3}\pi \left(\frac{2}{3}y\right)^2 y$ . Simplifying, we get the formula

$$V = \frac{4}{27}\pi y^3 \text{ in}^3.$$

- (f) Now suppose the coffee **mug** is one-third full of coffee. How fast is the height of coffee in the funnel changing? In other words, what is  $\frac{dy}{dt}$  at that instant?

**Solution:** The volume of the mug is  $9\pi \text{ in}^3$ , so when the mug is one-third full there will be  $3\pi$  cubic inches of coffee in it, and  $1\pi$  cubic inches of coffee left in the funnel. (The total amount of coffee in the system is  $4\pi$  cubic inches.)

Differentiating the volume formula, we get

$$\frac{dV}{dt} = \frac{4}{9}\pi y^2 \frac{dy}{dt}.$$

So to solve for  $\frac{dy}{dt}$  we need to plug in values for  $\frac{dV}{dt}$  and also for  $y$ . The value for  $\frac{dV}{dt}$  is given; it is  $-0.1 \text{ in}^3/\text{s}$ .

To find  $y$ , we use the volume formula from part (e) again. We need to know what  $y$  is when  $V = \pi$ . In that case, we can divide by  $\pi$  on both sides to get

$$1 = \frac{4}{27}y^3,$$

which you can solve:

$$y = \frac{3}{4^{1/3}} \approx 1.89.$$

Now we can solve for  $\frac{dy}{dt}$ :

$$-0.1 = \frac{4}{9}\pi(1.89)^2 \frac{dy}{dt},$$

which means that  $\frac{dy}{dt} \approx -0.02$  inches/second.